

A-1988 A

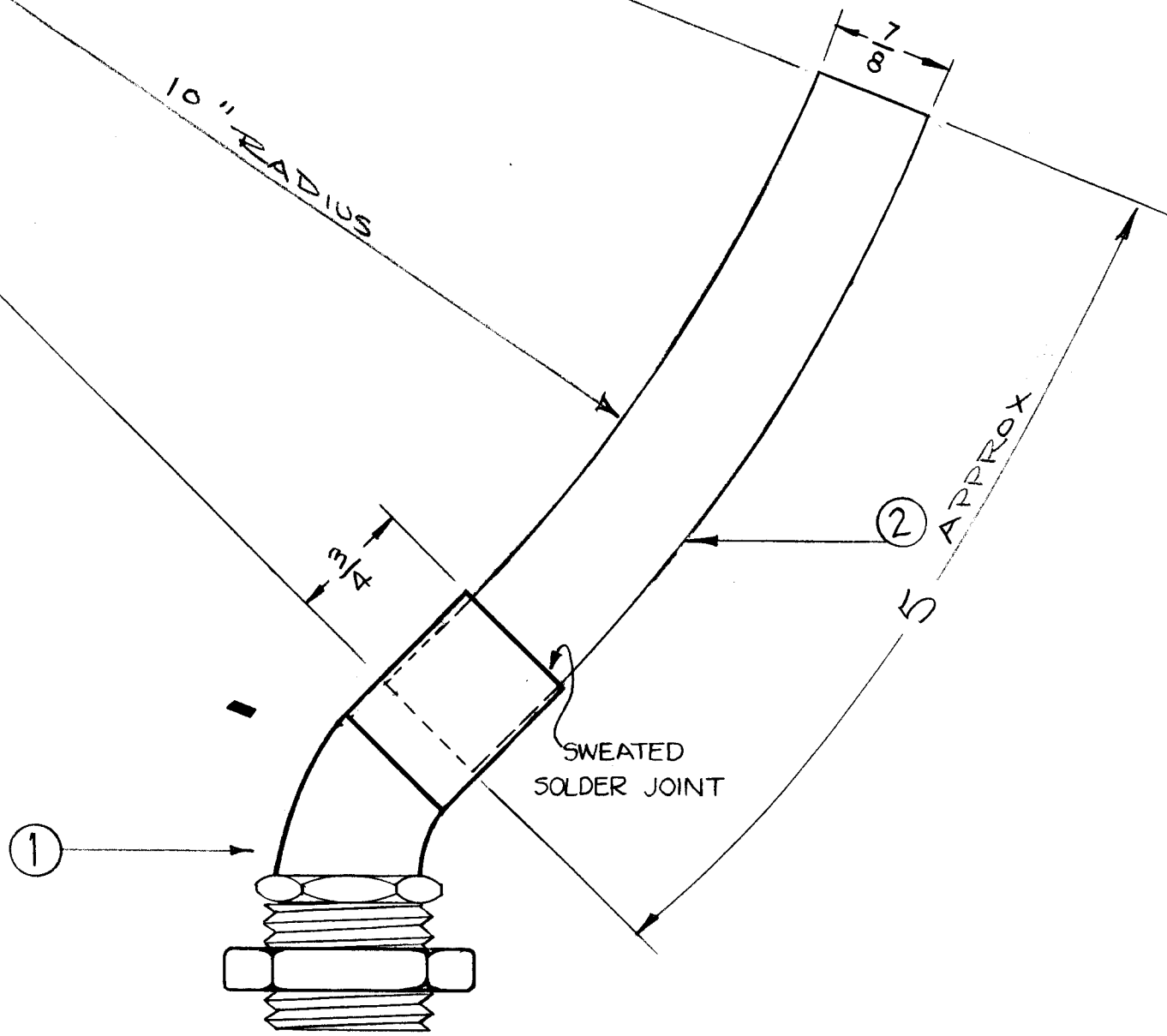

NOTE
FORM TUBING BEFORE
ASSEMBLING TO ELBOW

FINISH NOTE -
NICKEL PLATE - .0005
THREADS - .0002

4 1/2" Z	TU-100-14-N	TUBING, COPPER	
1	1	PO-167	ELBOW, 45°; ADAPTOR, 3/4" NUT
REQ. ITEM	PART NO.	DESCRIPTION	SYMBOL
STOCK SIZE		THE TECHNICAL MATERIEL CORP. MAMARONECK, NEW YORK	
MATERIAL		JET, AIR ASS'Y	
TYPE & TEMPER		HEAT TREAT. SPEC.	DRAWN
SEE NOTE			CHECKED
FINISH & SPEC. NO.		ELEC. DES. APP.	MECH. DES. APP.
			A-1988 A

DEC. DIM. ±	MAXIMUM ALLOWABLE TOLERANCES HAVE BEEN DETERMINED AND ANY DEVIATIONS WILL BE CAUSE FOR REJECTION.					
FRAC. DIM. ± 1/64	REMOVE ALL BURRS AND SHARP EDGES					
ANGULAR DIM. ±						
SCALE: <i>1/2" = 1"</i>						
ISSUE ITEM	CHANGED FROM	DATE	CH. NO.	DRAFTS	CHECKER	ENG. APP.
A 1	RADIUS Added	10/20/60	3240	RH	<i>JRL</i>	<i>AM</i>

1	GPT-40K	AX-209	10-3-60
REQ. PER UNIT	MODEL	PROJECT NO.	ASS'Y. NO.
USED ON			