

REQ. PER UNIT 1EA.	M DEL RTC	USED ON ASSY. NO. A-1265
		DATE A-11-36

NO. 33 (.113) DRILL 2 REQ.

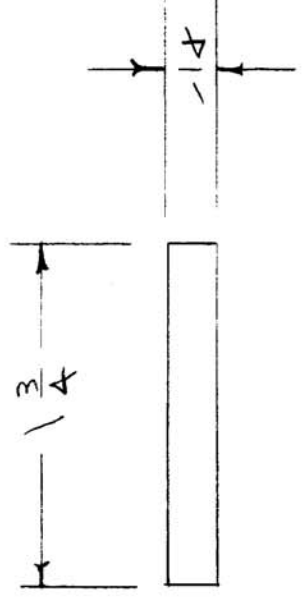
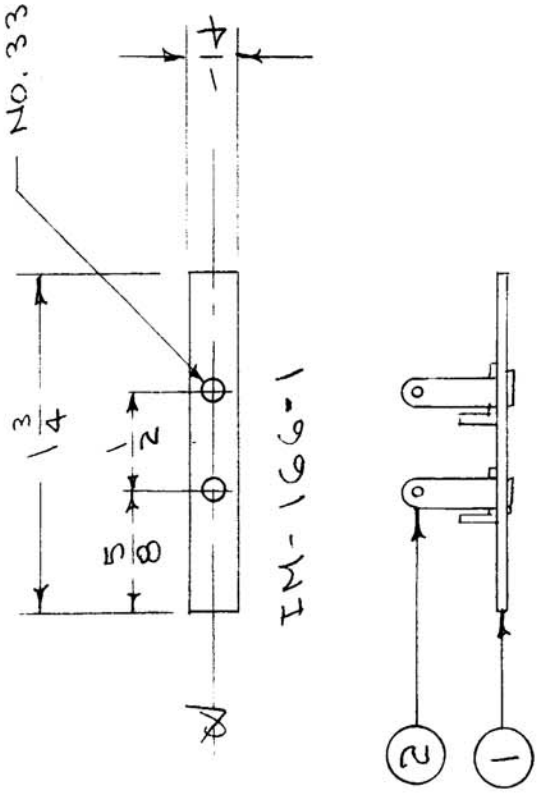

IM-166-2

REQ. ITEM 2	TE-145	PART NO.	DESCRIPTION TERMINAL STRIP (NO DWG)	SYMBOL
1	IM-166	.015	TERMINAL STRIP (NO DWG)	
FISH PAPER		STOCK SIZE	THE TECHNICAL MATERIEL CORP. MAMARONECK. NEW YORK	
MATERIAL			TERMINAL STRIP ASSY.	
TYPE & TEMPER		HEAT TREAT. SPEC.	DRAWN JWB	CHECKED JWB
FINISH & SPEC. NO.			ELEC. DES. APP. AB	MECH. DES. APP. AB
			DATE 3/20/36	FINAL APPROVAL JWB
				A-1265

ISSUE ITEM	CHANGED FROM	DATE	CH. NO.	DRAFTS	CHECKER	ENG. APP.
TOLERANCES						
DEC. DIM. \pm						
FRAC. DIM. \pm						
ANGULAR DIM. \pm						
SCALE:						
MAXIMUM ALLOWABLE TOLERANCES HAVE BEEN DETERMINED AND ANY DEVIATIONS WILL BE CAUSE FOR REJECTION.						
REMOVE ALL BURRS AND SHARP EDGES						