

IF IT IS FOUND DESIRABLE TO CHANGE ANY TOLERANCE OR OTHER DETAIL SPECIFIED ON THIS DRAWING NOTIFY THE PURCHASER PROMPTLY.

MAXIMUM ALLOWABLE TOLERANCES HAVE BEEN DETERMINED AND DEVIATIONS WILL BE CAUSE FOR REJECTION. REMOVE ALL BURRS AND SHARP EDGES

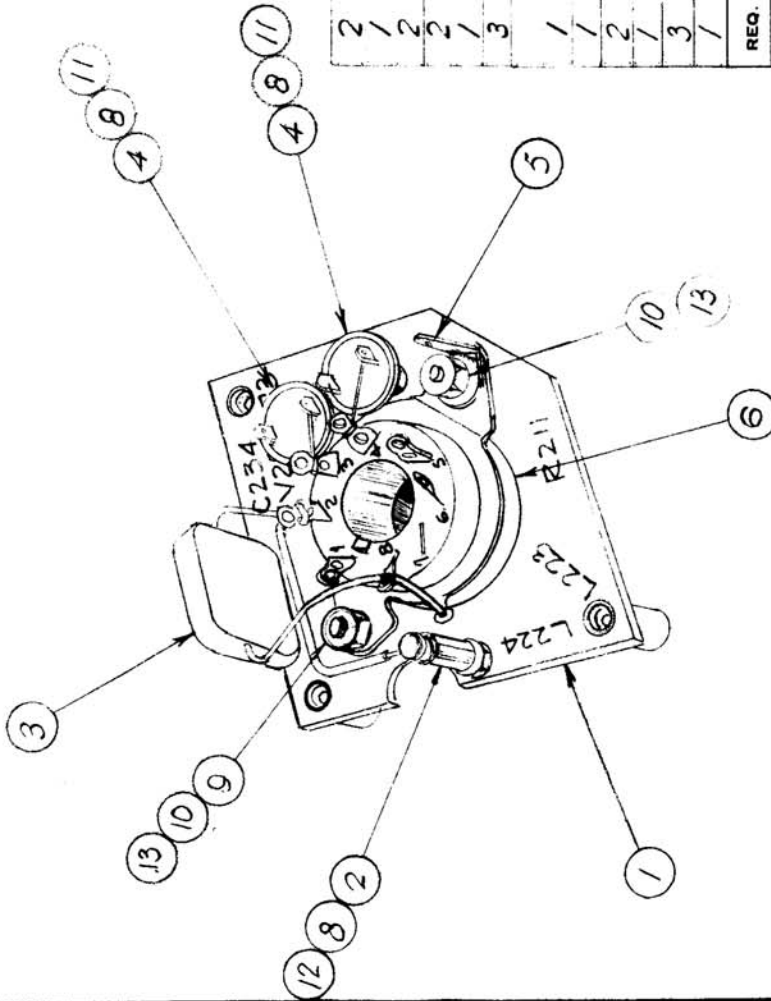

NOTICE TO PERSONS RECEIVING THIS DRAWING

THE TECHNICAL MATERIEL CORPORATION claims proprietary right in the material disclosed hereon. This drawing is issued in confidence for your information only and may not be re-used or distributed to manufacture without the written permission of THE TECHNICAL MATERIEL CORPORATION to the contrary. This drawing is issued for your assistance and is subject to recall at any time.

Property of:

THE TECHNICAL MATERIEL CORPORATION
MAMARONECK, NEW YORK

REQ.	ITEM	PART NO.	DESCRIPTION	SYMBOL
2	13	SCBS0632BN5	SCREW	
1	12	SCBS0440BN3	SCREW	
2	11	SCBS0348BN3	SCREW	
2	10	NITH0632BN8	NUT	
1	9	LWED06MRN	WASHER	
3	8	LWED04MRN	WASHER	
1	6	TS-101-PO1	TUBE SOCKET	Y202
1	5	TE-104-2	GROUND LUG	
2	4	CB21QW102K	CAPACITOR	C233 C2B3
1	3	CM35C103J	CAPACITOR	C234
3	2	TE-102-2	STANDOFF	
1	1	LD-10099	PLATE	

STOCK SIZE	WEIGHT PER PC.

MATERIAL	TYPE & TEMPER	HEAT TREAT. SPEC.	FINISH & SPEC. NO.

TYPE & TEMPER	HEAT TREAT. SPEC.	FINISH & SPEC. NO.

TYPE & TEMPER	HEAT TREAT. SPEC.	FINISH & SPEC. NO.

TYPE & TEMPER	HEAT TREAT. SPEC.	FINISH & SPEC. NO.

TYPE & TEMPER	HEAT TREAT. SPEC.	FINISH & SPEC. NO.

TYPE & TEMPER	HEAT TREAT. SPEC.	FINISH & SPEC. NO.

TYPE & TEMPER	HEAT TREAT. SPEC.	FINISH & SPEC. NO.

TYPE & TEMPER	HEAT TREAT. SPEC.	FINISH & SPEC. NO.

TYPE & TEMPER	HEAT TREAT. SPEC.	FINISH & SPEC. NO.

TYPE & TEMPER	HEAT TREAT. SPEC.	FINISH & SPEC. NO.

A-10307A

USED ON

PROJECT NO. ASS'Y. NO. DATE

RF-A-1 28 FEB 67

WHDAMISON

DRAWN

ELEC. DES. APP.

MECH. DES. APP.

CHECKED

FINAL APPROVAL

A-10307

△

ISSUE	ITEM	CHANGED FROM	DATE	CN. NO.	DRAFTS	CHECKER	ENG. APP.
A	2	SYMBOLS ADDED	10-12-62	7429	CH	WDR	WDR
	1	ITEMS RELOCATED FROM PING TO					