

IF IT IS FOUND DESIRABLE TO CHANGE ANY TOLERANCE OR OTHER DETAIL SPECIFIED ON THIS DRAWING NOTIFY THE PURCHASER PROMPTLY.

MAXIMUM ALLOWABLE TOLERANCES HAVE BEEN DETERMINED AND DEVIATIONS WILL BE CAUSE FOR REJECTION. REMOVE ALL BURRS AND SHARP EDGES

A-137

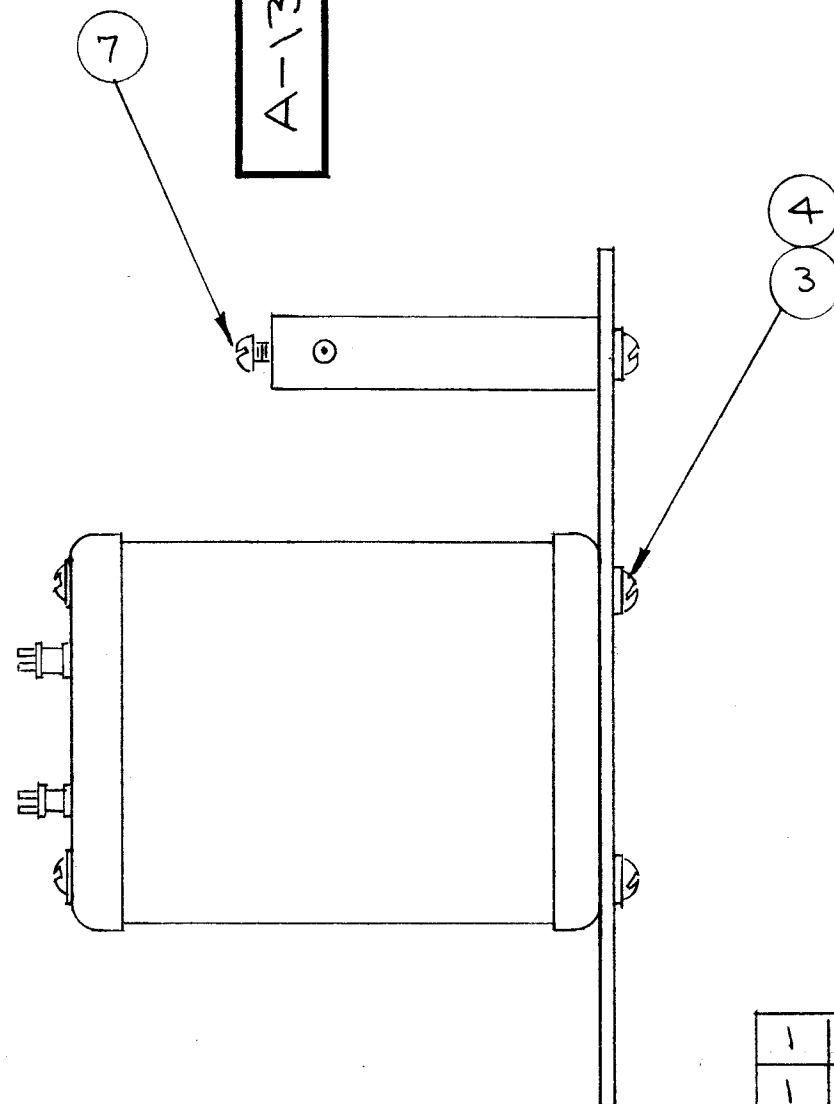
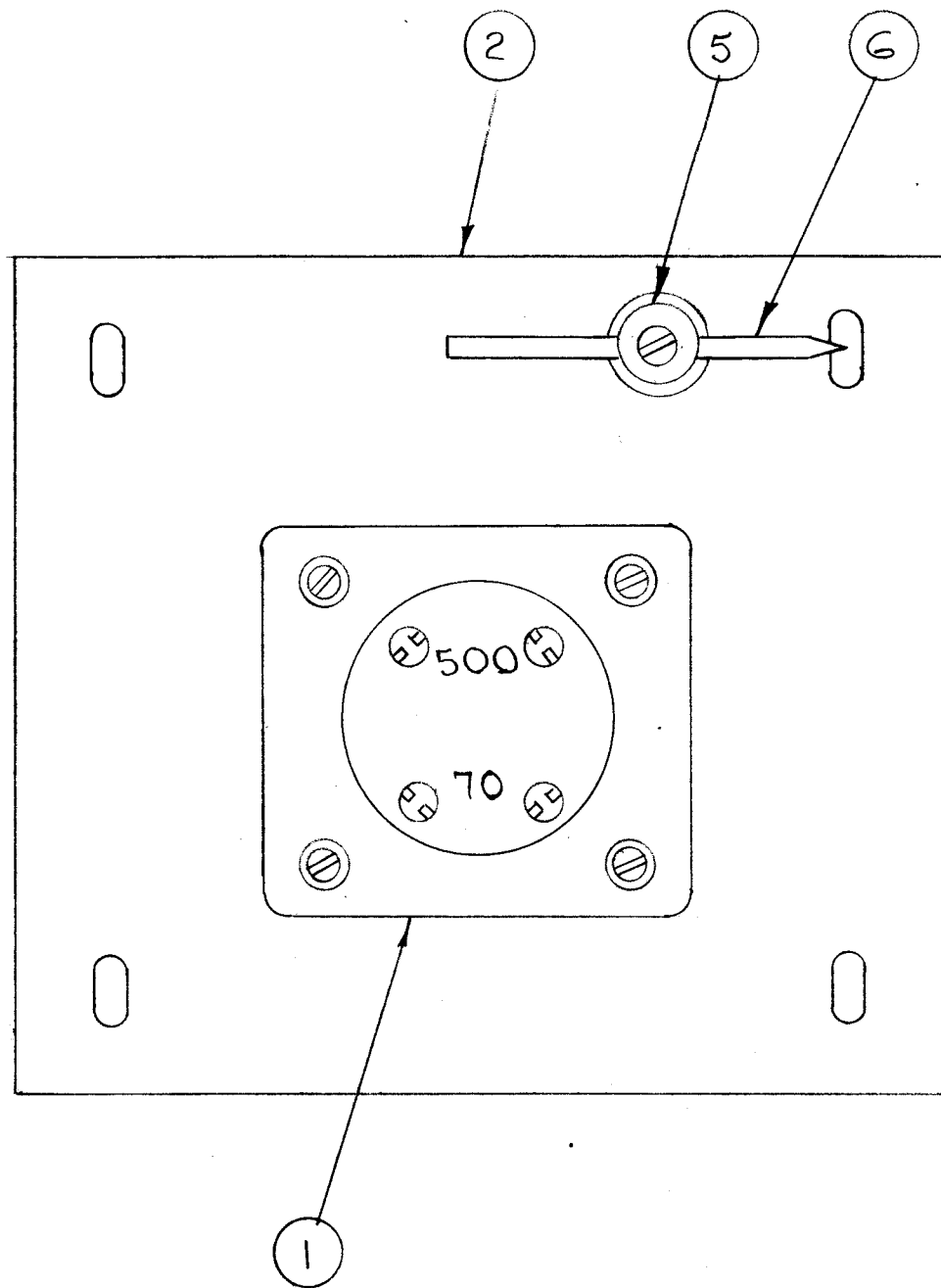

REQ.	ITEM	PART NO.	DESCRIPTION	SYMBOL
1	7	SCRS0632SNG	SCREW, MACHINE	
1	6	PM-103	SPARK ROD	
1	5	PM-102	POST	
4	4	LWEO6MRC	WASHER, LOCK	
4	3	SCBS0632BNG	SCREW, MACHINE	
1	2	MS-109	MOUNTING PLATE	
1	1	TR-018	TRANSFORMER, RF	

THE TECHNICAL MATERIEL CORP.  
MAMARONECK, NEW YORK

TRANSFORMER & PLATE  
SUB-ASSY

DRAWN \_\_\_\_\_ ELEC. DES. APP. \_\_\_\_\_ MECH. DES. APP. \_\_\_\_\_

CHECKED \_\_\_\_\_ FINAL APPROVAL \_\_\_\_\_

A-137

ISSUE	ITEM	CHANGED FROM	DATE	CN. NO.	DRAFTS	CHECKER	ENG. APP.
		Redrawn - No Revision	7-23-53	1		JAG	F.M.

TOLERANCES: DEC. DIM. ±, FRAC. DIM. ±, ANGULAR DIM. ±

SCALE: FULL

DRILL, PUNCH, COMMERCIAL STOCK SIZES AND MANUFACTURERS TOLERANCES ARE NOT INCLUDED.

BAC-3-S500	153	A-234	9/5/53
MODEL	PROJECT NO.	ASSY. NO.	DATE

USED ON